

MAX. PAYLOAD: 3.5 tonnes (7716lb) MAX. LIFT HEIGHT: 9.5 metres (31ft 2in)

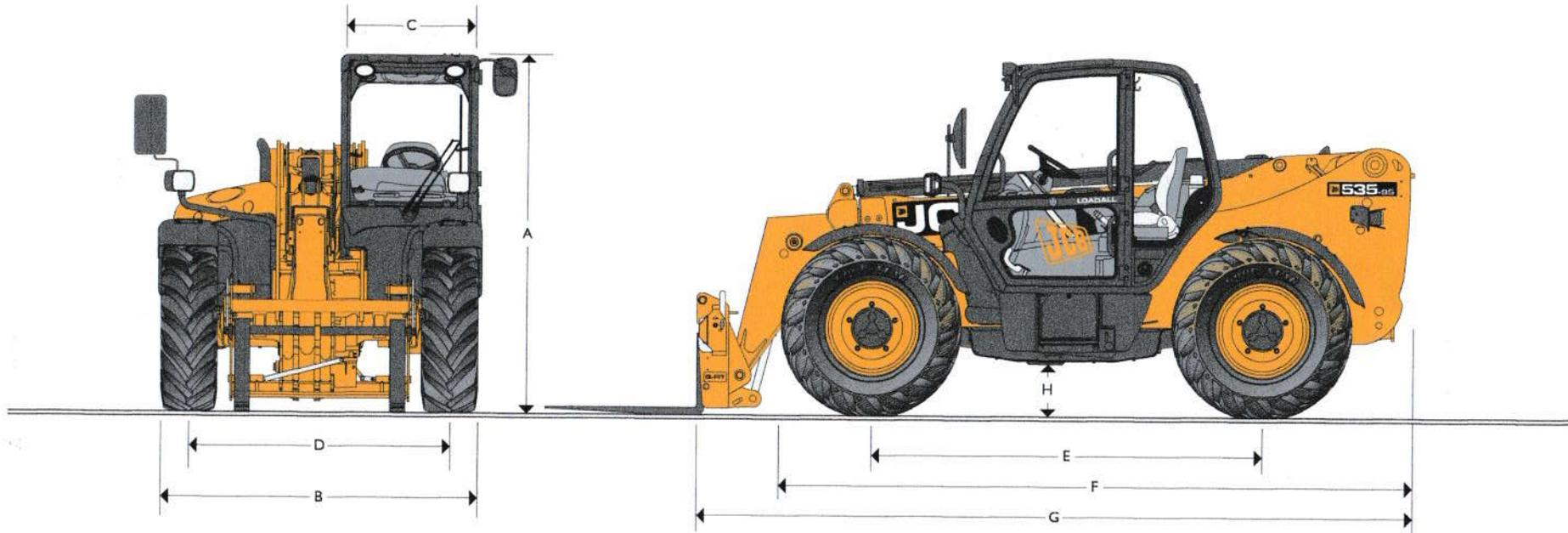

STATIC DIMENSIONS

Machine model	535-95
	m (ft-in)
A Overall height	2.49 (8-2)
B Overall width (over tyres)*	2.29 (7-6)
C Inside width of cab	0.94 (3-1)
D Front track	1.87 (6-1)
E Wheelbase	2.75 (9-0)
F Overall length to front tyres	4.38 (14-4)
G Overall length to front carriage	4.99 (16-4)

*Dependant upon tyre specified.

Machine model	535-95
	m (ft-in)
H Ground clearance	0.40 (1-4)
Outside turn radius (over tyres)	3.7 (12-2)
Carriage roll back angle	degrees 41.2
Carriage dump angle	degrees 24.1
Weight – Fixed	kg (lb) 8160 (17989)
Weight – Sway	kg (lb) 8215 (18110)
Tyres	15.5/80-24

LIFT PERFORMANCE – 535-95

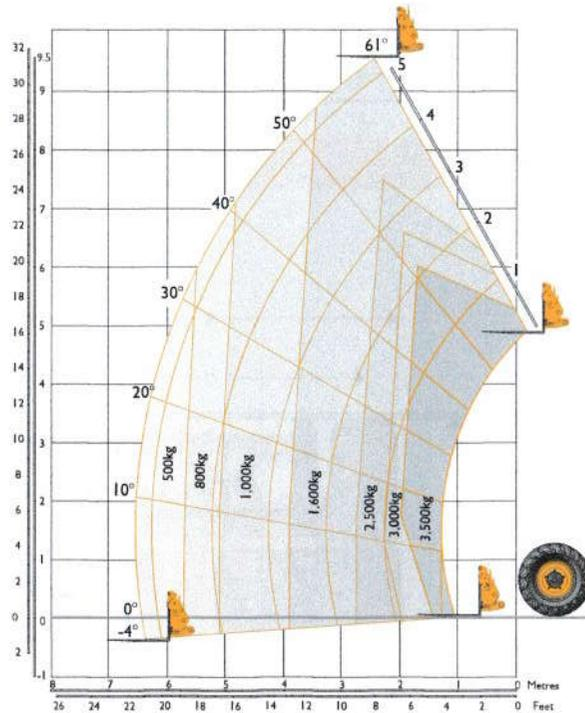

LIFT PERFORMANCE – 535-95 SWAY

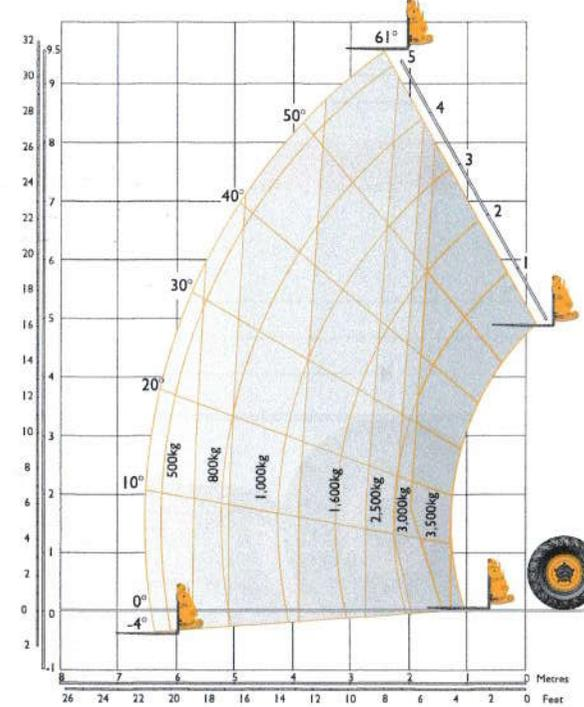

Chassis Levelling (Sway)

LIFT PERFORMANCE – 535-95

Machine Model		535-95
Maximum lift capacity	kg (lb)	3500 (7716)
Lift capacity to full height	kg (lb)	1600 (3527)
Lift capacity at full reach	kg (lb)	500 (1102)
Lift height	m (ft-in)	9.50 (31-2)
Reach at maximum lift height	m (ft-in)	2.43 (7-11)
Maximum forward reach	m (ft-in)	6.52 (21-5)
Reach with 1 tonne load	m (ft-in)	5.08 (16-8)
Placing height	m (ft-in)	8.78 (28-9)

Complies with stability test EN 1459 Annex B.

LIFT PERFORMANCE – 535-95 SWAY

Machine Model		535-95 Sway
Maximum lift capacity	kg (lb)	3500 (7716)
Lift capacity to full height	kg (lb)	1600 (3527)
Lift capacity at full reach	kg (lb)	500 (1102)
Lift height	m (ft-in)	9.50 (31-2)
Reach at maximum lift height	m (ft-in)	2.43 (7-11)
Maximum forward reach	m (ft-in)	6.52 (21-5)
Reach with 1 tonne load	m (ft-in)	5.08 (16-8)
Placing height	m (ft-in)	8.78 (28-9)

Complies with stability test EN 1459 Annex B.



ENGINE

Latest technology and advanced design provides low fuel consumption, reduced noise, high torque and power output, total reliability and minimal maintenance. Two-stage, dry type air filter with primary and safety elements. Territory dependent.

		Standard	Standard	Option	Option
Engine standard		Stage II	Stage III	Stage II	Stage III
Manufacturer		JCB	JCB	JCB	JCB
Displacement	ltr (in ³)	4.4 (269)	4.4 (269)	4.4 (269)	4.4 (269)
No. of cylinders		4	4	4	4
Bore size	mm (in)	103 (4.05)	103 (4.05)	103 (4.05)	103 (4.05)
Stroke	mm (in)	132 (5)	132 (5)	132 (5)	132 (5)
Aspiration		Naturally aspirated	Turbo	Turbo	Turbocharged cooled
Power rating					
Power @ 2200rpm	kW (HP)	63 (85)	63 (85)	74.2 (100)	74.2 (100)
Torque rating					
Torque @ 1200rpm	Nm (lbf ft)	320 (236)	362 (267)	–	–
Torque @ 1300rpm	Nm (lbf ft)	–	–	425 (313)	440 (324)

TRANSMISSION

JCB powershift transmission incorporating torque converter, bevel box and a 4 speed powershift gearbox in one resiliently mounted unit.

A combined steering column mounted switch incorporating directional control and 4 forward and 4 reverse powershift gears. Travel speed 29kph (18mph), 33kph (20mph) when 2/4WD select is specified.

Front and rear drive axles: JCB epicyclic hub reduction drive/steer axles with Max-Trac torque proportioning differentials. Permanent 4 wheel drive.

BRAKES

Service brakes: Servo-assisted-hydraulically activated, self-adjusting, oil-immersed in-board multi-disc type on front axle.

Parking brake: Hand operated disc brake on output of gearbox.

BOOM AND CARRIAGE

Boom is manufactured from high tensile steel.

Low maintenance, hard wearing pads.

JCB Q-fit self-levelling carriage with lever operated pin locking accepts pallet forks and a wide range of attachments.

One boom end auxiliary hydraulic service fitted as standard.

SAFETY CHECK VALVES

Fitted to carriage tilt, telescopic and boom lift rams.

SERVICE CAPACITIES

Fuel tank	litres (UK gal)	146 (32.1)
Hydraulic tank	litres (UK gal)	113 (24.8)
Coolant	litres (UK gal)	23 (5.1)

HYDRAULICS

Gear pump with suction strainer and filter.

Operating system pressure	bar (psi)	241 (3500)
Main hydraulic flow	litres/min	82
Hydraulic Cycle Times	Seconds	
Boom raise		9.1
Boom lower		7.7
Extend		10.5
Retract		11.2
Bucket dump		2.4
Bucket crowd		3.5

ELECTRICS

12 v negative earth, 95 AH battery. 95 amp alternator. Full road lighting. Reversing light. Direction indicators. Hazard warning. Reverse alarm.

CAB

Quiet safe and comfortable cab conforms to ROPS ISO 3471 and FOPS ISO 3449. Tinted glass all round. Laminated roof screen. Roof bars, front, rear and roof screen wash/wipe and heater/screen demister. Opening rear window. Audio-visual warning system for coolant temperature, engine oil pressure, air cleaner, battery charge, transmission oil temperature and pressure, water in fuel, Hourmeter and road speed indicator, engine temperature, fuel gauge, clock and inclinometer.

Mechanical joystick, direct acting hydraulic control levers. Adjustable steer column with stalk bar powershift change and forward reverse shuttle. Throttle and brake pedal. Adjustable deluxe seat with adjacent park brake fitted.

Automatic eye level audio-visual load moment indicator warning system receiving a signal from a load sensor on the rear axle.

This system continuously monitors the machine's forward stability and leaves the operator in control at all times.

Safety canopy as above but with side glass only (screen wiper and heater/screen demister not applicable).

STEERING

Hydrostatic power steering with power track rods on both axles.

Three steer mode options: front wheel steer; all wheel steer; crab steer: operated from in the cab by a selection switch.

OPTIONS AND ACCESSORIES

Options: Front and rear working lights, rotating flashing beacon, fire extinguisher, traction and industrial tyres, electrical 2/4WD select, limited slip differential in front axle, windscreen and roof guard, air suspension seat, deluxe cab trim, roof and front screen blind, radio kit, air conditioning, reversing fan, roof moulding.

Single lever joystick with push button extend and retract.

Attachments: Contact your local dealer for details of the comprehensive range.

*Adaptive Load Control for EU territories conforms to EN15000.



A GLOBAL COMMITMENT TO QUALITY

JCB's total commitment to its products and customers has helped it grow from a one-man business into Britain's largest privately owned manufacturer of backhoe loaders, crawler excavators, wheeled excavators, telescopic handlers, wheeled loaders, dump trucks, rough terrain fork lifts, industrial fork lifts, mini/midi excavators, skid steer loaders, tractors and compaction equipment.

By making constant and massive investments in the latest production technology, the JCB factories have become some of the most advanced in the world.

By leading the field in innovative research and design, extensive testing and stringent quality control, JCB machines have become renowned all over the world for performance, value and reliability.

And with a global sales and service network of more than 650 dealers and agents, we aim to deliver the best customer support in the industry.

Through setting the standards by which others are judged, JCB has become one of the world's most impressive success stories.

