

906H, 907H, 908H

Compact Wheel Loaders

CATERPILLAR®



Cat® C3.4 Engine

Net Power (SAE J1349)

906H

52 kW (70 hp)

907H

52 kW (70 hp)

908H

59 kW (79 hp)

Weights

Operating Weight

5630 kg (12,412 lb)

5810 kg (12,809 lb)

6465 kg (14,253 lb)

Buckets

Bucket Capacities

0.75 – 1.2 m³ (0.98 – 1.6 yd³)

0.75 – 1.2 m³ (0.98 – 1.6 yd³)

0.9 – 1.5 m³ (1.2 – 2.0 yd³)

906H, 907H, 908H Features

High Performance

With its high full turn tipping loads and breakout forces, the H-Series delivers a powerful solution for all customer applications.

Ease of Operation

Operating the H-Series Compact Wheel Loader couldn't be easier. Simple controls and the ergonomically designed, low effort joystick reduce fatigue and increase comfort.

Power Train

The standard hydrostatic driveline is a 20 km/h (12.4 mph) transmission. Heavy duty axles and 100% diff-lock are standard with ride control and 35 km/h (21.7 mph) high speeder available as options.

High Flow Work Tools

The standard skid steer loader style coupler combined with standard flow or optional high flow hydraulics allow the Cat® Compact Wheel Loaders to use a large range Cat Work Tools including hydromechanical work tools.



Contents

Operator Station	3
Power Train	4
Loader Linkage	4
Work Tools	5
Serviceability.....	6
Customer Support.....	6
Specifications	7
Standard and Optional Equipment.....	10
Notes	11

The Cat® 906H, 907H and 908H Compact Wheel Loaders deliver high performance with outstanding versatility. Spacious cab with joystick control keeps you comfortable throughout the work day, allowing you to get more done. Loader design delivers strength and durability with superior control. Do more with one machine with the new skid steer loader style coupler. This coupler allows the use of Cat Skid Steer, Multi Terrain and Compact Track Loader hydromechanical work tools on the Cat Compact Wheel Loader for greater machine versatility. Expand your business with the Cat H-Series Compact Wheel Loaders.



Operator Station

Superior comfort keeps you productive, all day long.

Cab Comfort

Spacious, comfortable cab helps you stay productive throughout the work day. Low effort joystick and steering, intuitively laid out controls, two arm rests and an adjustable wrist rest are some of the many features built into the H-Series Compact Wheel Loader for maximum operator comfort. A variety of options makes it easy to customize the cab to your requirements. Select the operator station that meets your needs – Canopy, Comfort Cab or Deluxe Cab. Optional air conditioning system is available for additional operator comfort. All cabs are pre-wired, making it easy to install future options.

Low Effort Controls

Pilot hydraulics keep operator fatigue low. The single multi functional joystick contains FNR (Forward/Neutral/Reverse), travel speed, third function auxiliary hydraulics (for hydromechanical work tools), differential lock and continuous flow controls.

Excellent Visibility

Work site visibility has been maximized with two fully glazed doors, front low-level glazing, excellent rear visibility and a clear view to the work tool through the loader arms.

Low Cab Height on the 906H

The 906H features a low cab height of 2465 mm (8 ft 1 in) to provide access to more areas on the job site.

Power Train

Cat[®] Hystat[™] power train delivers aggressive performance.

Cat Engine

The Cat C3.4 engine delivers superior power to help you get more done.

Chassis/Undercarriage

Oscillating chassis helps assure four wheel ground contact for optimum traction and stability. Heavy duty axles with outboard planetary reduction gears are built for durable performance. Differential lock in both axles is standard and can be easily engaged on the move to allow travel over poor underfoot conditions.

Two Speed Options

The Cat hydrostatic drive line offers two speed ranges: 20 km/h (12.4 mph) or 35 km/h (21.7 mph). The optional speeder transmission provides a maximum speed of 35 km/h (21.7 mph) using an optional two-speed gearbox. Both versions feature smooth inching as standard. Optional speed (creeper) control, rimpull control and hand throttle are also offered (transmission control upgrade).

Ride Control

The optional Ride Control system further enhances the already smooth road handling of the machine, resulting in increased operator comfort and higher productivity. It is suited for extreme applications where operators need to maintain bucket material load or carry a heavy work tool and have a smooth ride. Three modes are available – auto, on and off. Also recommended if the machine is equipped with the 35 km/h (21.7 mph) speeder option.



Loader Linkage

Optimal digging forces with parallel lift.

Parallel Lift Z-Bar Design

The high performance Z-bar loader design is built for strength and excellent work tool visibility. The standard skid steer loader style quick coupler ensures maximum versatility. The Z-bar linkage gives the operator a clear view to the work tool and excellent dump clearance while maintaining good cycle times and parallel lift.



Work Tools

Do more jobs with one machine with Cat Work Tools.

The Right Tool for the Job

Increase the versatility of the machine with the wide range of Cat buckets, forks and hydraulically powered work tools. Work tools can be changed quickly and easily with the machine's quick coupler system. Available work tools include:

- Buckets
- Forks
- Augers
- Brooms
- Cold Planers
- Landscape Rakes
- Landscape Tillers
- Material Handling Arm
- Power Box Rakes
- Snow Removers
- Stump Grinders
- Trenchers
- Vibratory Compactors

For a complete list of available work tools, please consult your Cat dealer.

Skid Steer Loader Style Coupler

The universal skid steer loader style coupler allows the use of many Cat Skid Steer, Multi Terrain and Compact Track Loader hydromechanical work tools. Auxiliary lines and connectors are standard equipment. Using either the standard flow or optional high flow hydraulics, this coupler system allows the H-Series Compact Wheel Loaders to easily integrate into a Cat Skid Steer, Multi Terrain or Compact Track Loader fleet.

Additional Options to Increase Productivity

Caterpillar offers the following options to further increase your productivity:

- Return to dig work tool positioner automatically returns the bucket to level position after dumping.
- Work tool wiring harness for fourth hydraulic function such as broom angling.
- Transmission control upgrade includes speed control, rimpull control and hand throttle control. Speed control (creeper) provides variable control of ground speed while maintaining optimal hydromechanical work tool speed. Rimpull control optimizes bucket loading and reduces wheel spin under various material conditions. Hand throttle control provides infinitely variable means of fixing engine speed, ideal for steady operation of hydromechanical work tools.
- High flow auxiliary hydraulics at 125 L/min (33 gal/min) for high flow work tools.



Serviceability

Easy access and minimal maintenance requirements reduce downtime.



Convenient Service Features

High opening, easy to lift engine hood and side service doors provide easy access to all major components and service points from ground level.

- Valves and pressure taps are conveniently located in the engine bay for S•O•SSM analysis of engine and hydraulic system cleanliness and service requirements, prolonging machine life.
- Two stage air cleaner with a built-in centrifugal pre-cleaner, secondary element and a visual restriction indicator improves service life.
- Auxiliary fuses, diagnostic sockets, master disconnect switch and other regular service points are all located together for ease of servicing.
- Spin-on engine and hydraulic oil filters and fuel filter with water separator are vertically mounted for easier servicing.
- Heavy-duty wiring increases electrical durability and is multicolored to ease diagnosis and fault finding. Water resistant sealed connectors prevent dust and moisture from interfering with the electronics.
- Hydraulic oil cooler swings out using a handle in the engine bay for easy access to the radiator and cooler for cleaning.
- Electronic Technician allows advanced diagnostics and fault code investigation using Cat service tools.

Customer Support

Unmatched support makes the difference.

Superior Dealer Service

Your Cat dealer is ready to assist you with your purchase decision and everything after.

- Make comparisons of machines, with estimates of component life, preventative maintenance and cost of production.
- Financing packages are flexible to meet your needs.
- Your Cat dealer can evaluate the cost to repair, rebuild and replace your machine, so you can make the right choice.
- For more information on Cat products, dealer services and industry solutions, visit us at www.cat.com.



906H, 907H, 908H Compact Wheel Loader Specifications

Engine

Model	Cat® C3.4	
Gross Power @ 2,500 rpm – 906H/907H	55 kW	74 hp
Gross Power @ 2,500 rpm – 908H	62 kW	83 hp
Net power @ 2,500 rpm – 906H/907H	52 kW	70 hp
Net Power @ 2,500 rpm – 908H	59 kW	79 hp
Bore	94 mm	3.7 in
Stroke	120 mm	4.7 in
Displacement	3.3 L	203 in ³

- The Cat C3.4 engine meets Tier 3 emissions regulations.

Weights

Operating Weight – 906H	5630 kg	12,412 lb
Operating Weight – 907H	5810 kg	12,809 lb
Operating Weight – 908H	6465 kg	14,253 lb

Transmission

Travel Speed 1	7 km/h	4.3 mph
Travel Speed 2	20 km/h	12.4 mph
High Speed	35 km/h	21.7 mph

Cab

ROPS	SAE J1040 MAY94, ISO 3471-1994	
FOPS	SAE J/ISO 3449 APR98 Level II, ISO 3449 1992 Level II	

Hydraulic System

Main relief	235 bar	3,400 psi
3rd Auxiliary Flow, Standard Flow	83 L/min	22 gal/min
3rd Auxiliary Flow, High Flow	125 L/min	33 gal/min
Hydraulic cycle time – lift	5 Seconds	
Hydraulic cycle time – dump	2 Seconds	
Hydraulic cycle time – lower, float	4 Seconds	
Hydraulic cycle time – rackback	2.5 Seconds	

Service Refill Capacities

Cooling System	24 L	6.3 gal
Fuel Tank – 906H	52 L	13.7 gal
Fuel Tank – 907H/908H	78 L	20.6 gal
Hydraulic system	84 L	22.2 gal
Engine Oil	10 L	2.6 gal

Buckets

Bucket Capacities – 906H	0.75-1.2 m ³	0.98-1.6 yd ³
Bucket Capacities – 907H	0.75-1.2 m ³	0.98-1.6 yd ³
Bucket Capacities – 908H	0.9-1.5 m ³	1.2-2.0 yd ³

Operating Specifications

	906H		907H		908H	
Tire Size	405/70 R18		405/70 R18		405/70 R20	
Rated Bucket Capacity	0.9 m ³	1.18 yd ³	1.0 m ³	1.3 yd ³	1.1 m ³	1.4 yd ³
Hydraulic Lift Capacity	3263 kg	7,194 lb	3263 kg	7,194 lb	3569 kg	7,868 lb
Breakout force	42 kN	9,442 lb	42 kN	9,442 lb	47 kN	10,566 lb
Rated operating load @ full turn, bucket	1580 kg	3,483 lb	1585 kg	3,494 lb	1705 kg	3,759 lb
Straight tipping load, bucket	3985 kg	8,785 lb	4320 kg	9,524 lb	4775 kg	10,527 lb
Full turn static tipping load, bucket	3160 kg	6,967 lb	3170 kg	6,989 lb	3410 kg	7,518 lb
Rackback, transport position	52 Degrees		52 Degrees		52 Degrees	
Rated operating load @ full turn, forks (EN 474-3:2006, firm and level ground, 500 mm (20 in) load center) (80% of FTSTL)	2065 kg	4,553 lb	2120 kg	4,674 lb	2355 kg	5,192 lb
Rated operating load @ full turn, forks (EN 474-3:2006, rough terrain, 500 mm (20 in) load center) (60% of FTSTL)	1549 kg	3,415 lb	1590 kg	3,505 lb	1766 kg	3,893 lb
Rated operating load @ full turn, forks (EN 474-3:2006, firm and level ground, 500 mm (20 in) load center) (transport 100 mm (4 in) above ground)	2720 kg	5,997 lb	2785 kg	6,140 lb	2990 kg	6,592 lb

- Specifications shown are for 906H, 907H, and 908H with full fuel tank, 75 kg (165 lb) operator, ROPS/FOPS cab, skid steer loader style coupler and general purpose bucket.

Dimensions

All dimensions are approximate. Dimensions shown are based on the machine equipped with general purpose bucket and standard 405/70 SPT9 tires. Refer to Operating Specifications.

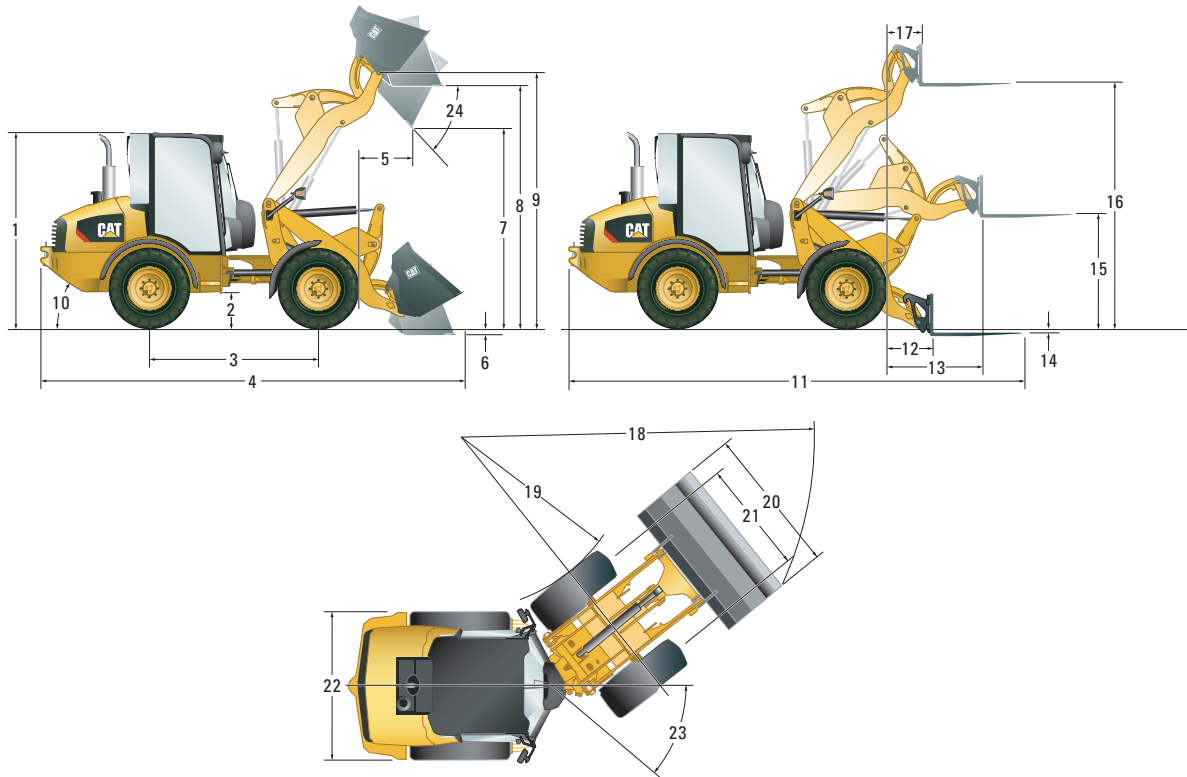

	906H	907H	908H
1 Cab Height	2465 mm (8 ft 1 in)	2585 mm (8 ft 6 in)	2650 mm (8 ft 8 in)
2 Ground Clearance	300 mm (11.8 in)	300 mm (11.8 in)	340 mm (13 in)
3 Wheelbase	2170 mm (7 ft 1 in)	2170 mm (7 ft 1 in)	2170 mm (7 ft 1 in)
4 Overall Length with Bucket	5585 mm (18 ft 4 in)	5585 mm (18 ft 4 in)	5760 mm (18 ft 11 in)
5 Reach at Max Dump Height	810 mm (2 ft 8 in)	810 mm (2 ft 8 in)	855 mm (2 ft 10 in)
6 Dig Depth	90 mm (3.5 in)	90 mm (3.5 in)	95 mm (3.7 in)
7 Max Dump Height	2395 mm (7 ft 10 in)	2395 mm (7 ft 10 in)	2540 mm (8 ft 4 in)
8 Load Over Height	3025 mm (9 ft 11 in)	3025 mm (9 ft 11 in)	3215 mm (10 ft 7 in)
9 Hinge Pin at Max Height	3230 mm (10 ft 7 in)	3230 mm (10 ft 7 in)	3410 mm (11 ft 2 in)
10 Departure Angle (degrees)	34°	34°	34°
11 Overall Length with Forks	5945 mm (19 ft 6 in)	5945 mm (19 ft 6 in)	6150 mm (20 ft 2 in)
12 Reach at Ground Level	750 mm (2 ft 6 in)	750 mm (2 ft 6 in)	925 mm (3 ft)
13 Max Reach	1265 mm (4 ft 2 in)	1265 mm (4 ft 2 in)	1445 mm (4 ft 9 in)
14 Fork Depth Above Ground	45 mm (1.8 in)	45 mm (1.8 in)	30 mm (1.2 in)
15 Fork Height at Max Reach	1490 mm (4 ft 11 in)	1490 mm (4 ft 11 in)	1525 mm (5 ft)
16 Max Fork Height	3160 mm (10 ft 4 in)	3160 mm (10 ft 4 in)	3300 mm (10 ft 10 in)
17 Fork Reach at Max Height	505 mm (1 ft 8 in)	505 mm (1 ft 8 in)	595 mm (1 ft 11 in)
18 Turning Radius Over Bucket	4445 mm (14 ft 7 in)	4515 mm (14 ft 10 in)	4560 mm (15 ft)
19 Turning Radius Inside Tire	2240 mm (7 ft 4 in)	2240 mm (7 ft 4 in)	2080 mm (6 ft 10 in)
20 Width Over Bucket	1880 mm (6 ft 2 in)	2035 mm (6 ft 8 in)	2060 mm (6 ft 9 in)
21 Tire Gauge	1420 mm (4 ft 8 in)	1420 mm (4 ft 8 in)	1570 mm (5 ft 2 in)
22 Machine Width	1840 mm (6 ft)	1840 mm (6 ft)	1985 mm (6 ft 6 in)
23 Articulation Angle	39°	39°	39°
24 Dump Angle at Max Height	45°	45°	45°

Maximum Material Densities

Based on ISO 7546:1983 and rated operating loads at full turn.

906H				
Bucket Type		General Purpose	Multi Purpose	Light Material
Rated Capacity	m ³ (yd ³)	0.9 (1.18)	0.75 (0.98)	1.2 (1.6)
Dump Height	mm (in)	2395 (94)	2470 (97)	2285 (90)
Maximum Material Density	kg/m ³ (lb/yd ³)	1755 (2,958)	2131 (3,592)	1208 (2,036)
Bucket Width	mm (in)	1880 (74)	1880 (74)	2080 (82)
907H				
Bucket Type		General Purpose	Multi Purpose	Light Material
Rated Capacity	m ³ (yd ³)	1.0 (1.3)	0.75 (0.98)	1.2 (1.6)
Dump Height	mm (in)	2395 (94)	2470 (97)	2285 (90)
Maximum Material Density	kg/m ³ (lb/yd ³)	1584 (2,670)	2149 (3,622)	1218 (2,053)
Bucket Width	mm (in)	2035 (80)	1880 (74)	2080 (82)
908H				
Bucket Type		General Purpose	Multi Purpose	Light Material
Rated Capacity	m ³ (yd ³)	1.1 (1.4)	0.9 (1.18)	1.5 (2.0)
Dump Height	mm (in)	2540 (100)	2630 (104)	2345 (92)
Maximum Material Density	kg/m ³ (lb/yd ³)	1549 (2,611)	1929 (3,251)	1034 (1,743)
Bucket Width	mm (in)	2060 (81)	2060 (81)	2080 (82)

Operator Environment Features

	Deluxe Cab	Comfort Cab	Canopy
Operator Environment Features			
Two access doors	●	●	
Fixed steering column			●
Adjustable steering column	●	●	
Vinyl suspension seat			●
Cloth suspension seat, arm rest		●	
Cloth electric air suspension seat, arm/head rest, lumbar support, heated back seat	●		
Left window – sliding	●	●	
Right window – sliding	●		
Heated rear window	●	●	
Coat hook	●	●	●
Cabin light	●	●	
Sun visor	●	●	●
Radio ready kit (wiring, speaker, antenna and grill)	●	●	
External mirrors (2) – knock back	●	●	●
Heater	●	●	
Storage tray	●	●	●
Storage box	●	●	●
Air conditioning	●		
Internal mirror	●	●	●
Optional Cab Features			
Cat radio/CD/MP3/WMA	●	●	
Rear blind	●	●	

906H, 907H, 908H Standard Equipment

Standard equipment may vary. Consult your Cat dealer for details.

TRANSMISSION

Transmission, 20 km/h (12.4 mph); standard axles with hydraulically actuated dry disc brakes

Transmission inching function

Hydrostatic drive

100% Differential Lock on both axles, selectable on the move

LOADER

Skid steer loader style hydraulic quick coupler

Proportional auxiliary hydraulic circuit

Loader arm float function

Connect under pressure hydraulic quick connector

Parallel lift Z-bar loader

ENGINE

C3.4 Tier 3 emissions certified

Two stage air cleaner with visual indicator

Cat Extended Life Coolant, protects to -36° C (-33° F)

Lockable engine compartments

Easy quick release fuel filter/water separator

Engine oil drain valve (non spill eco drain)

Closed circuit breather

ELECTRICAL

Master battery disconnect switch

Heavy duty battery, 12V

Engine cold start aid

Alternator, 90 amp

Service point connector for electronic diagnostics (ET)

Roading lights

Back up alarm

GENERAL

E-coat paint primer

Pressure test points

Recovery hitch and pin

Scheduled oil sampling (S•O•S) ports

Lockable fuel filler cap

OPERATOR ENVIRONMENT

Multifunction joystick with direction control

Proportional auxiliary control

Two external mirrors – knock back

Warning indicators for major systems

Easy clean cab floor

Cup holder

Sun visor

ROPS & FOPS

Adjustable wrist rest

Seat belt, 75 mm (3 in), retractable

Cabin light

Internal mirror

Auxiliary power sockets

Coat hook

On board digital LCD display cluster

Sound suppression

Heavy duty floor mat

Storage tray

Lockable storage box

906H, 907H, 908H Optional Equipment

Optional equipment may vary. Consult your Cat dealer for details.

TRANSMISSION

Transmission control upgrade (includes creeper control, rimpull control and hand throttle)

Ride control

Speeder, 35 km/h (21.7 mph) with secondary steering and front axle with hydraulically boosted oil immersed disc brakes

LOADER

High flow auxiliary hydraulics

Return to dig work tool positioner

ENGINE

Engine block heater, 120V

Cat extended life coolant, protects to -50° C (-58° F)

Precleaner for engine air filter

ELECTRICAL

Machine Security System (MSS)

Rotating beacon

Work tool wiring harness

Working lights, two front and two rear

GENERAL

Custom color paint

Rear light guard kit

Tire options including heavy duty tires

WORK TOOLS

For all work tools and standard/high flow options, consult your Cat dealer

OPERATOR ENVIRONMENT

Cat radio/CD/MP3/WMA

Rear sun screen

Canopy includes:

- Steering column, fixed

- Seat, adjustable suspension, vinyl

Cab, Comfort (pressurized) includes:

- Two doors (left door includes sliding window)

- Seat, adjustable suspension, cloth

- Steering column, tilt

- Heater with window, side and foot vents

- Heated rear window

- Wiper/washer front and rear

- Radio ready kit including speakers

Cab, Deluxe (pressurized) includes:

- Two doors (both doors include sliding windows)

- Seat, electric air suspension, lumbar support and heated back, cloth

- Steering column, tilt

- Air conditioning and heater with window, side and foot vents

- Heated rear window

- Wiper/washer front and rear

- Radio ready kit including speakers

906H, 907H, 908H Compact Wheel Loader

For more complete information on Cat products, dealer services, and industry solutions, visit us on the web at www.cat.com

© 2009 Caterpillar Inc.
All rights reserved
Printed in the U.S.A.

AEHQ6069 (10-2009)

Materials and specifications are subject to change without notice. Featured machines may include additional equipment. See your Cat dealer for available options.

CAT, CATERPILLAR, SAFETY.CAT.COM, their respective logos, "Caterpillar Yellow" and the "Power Edge" trade dress, as well as corporate and product identity used herein, are trademarks of Caterpillar and may not be used without permission.

CATERPILLAR®