

25T LIFT POINTS ON 4 CORNERS OF MACHINE

SUSPENSION SECTION

NEW SIDESHIFT TROLLEY DESIGN  
CAPABLE OF HANDLING C-HOOK  
ATTACHMENT OR FIXED FRAME ATTACHMENT

PROTECTIVE PLATE FOR EXPOSED  
CABLES/HYDRAULIC COMPONENTS

#### Machine Specifications

- 125HP John Deere Engine
- 4 Wheel Drive
- 4 Wheel Brake
- 4 Wheel Steer
- 1.8m Telescopic Stroke
- Fully Sideshifting Trolley
- Fixed Lifting Points on 4 Corner Beams
- Fully Remote Control
- Swivel Pivot Locking Pins To Allow MG Drive Onto Trailer
- Bumpstops & E-Stops on Each Corner
- Motion Beepers
- 4 Flashing Beacons
- 8 L.E.D. Worklights
- 1.5m Extension Stools
- Painted RAL 1023 Yellow
- 90,000kg Capacity @ 5% Duty Cycle

**COMBiLiFT**  
LIFTING INNOVATION

**PROJECT**  
DRY HIRE

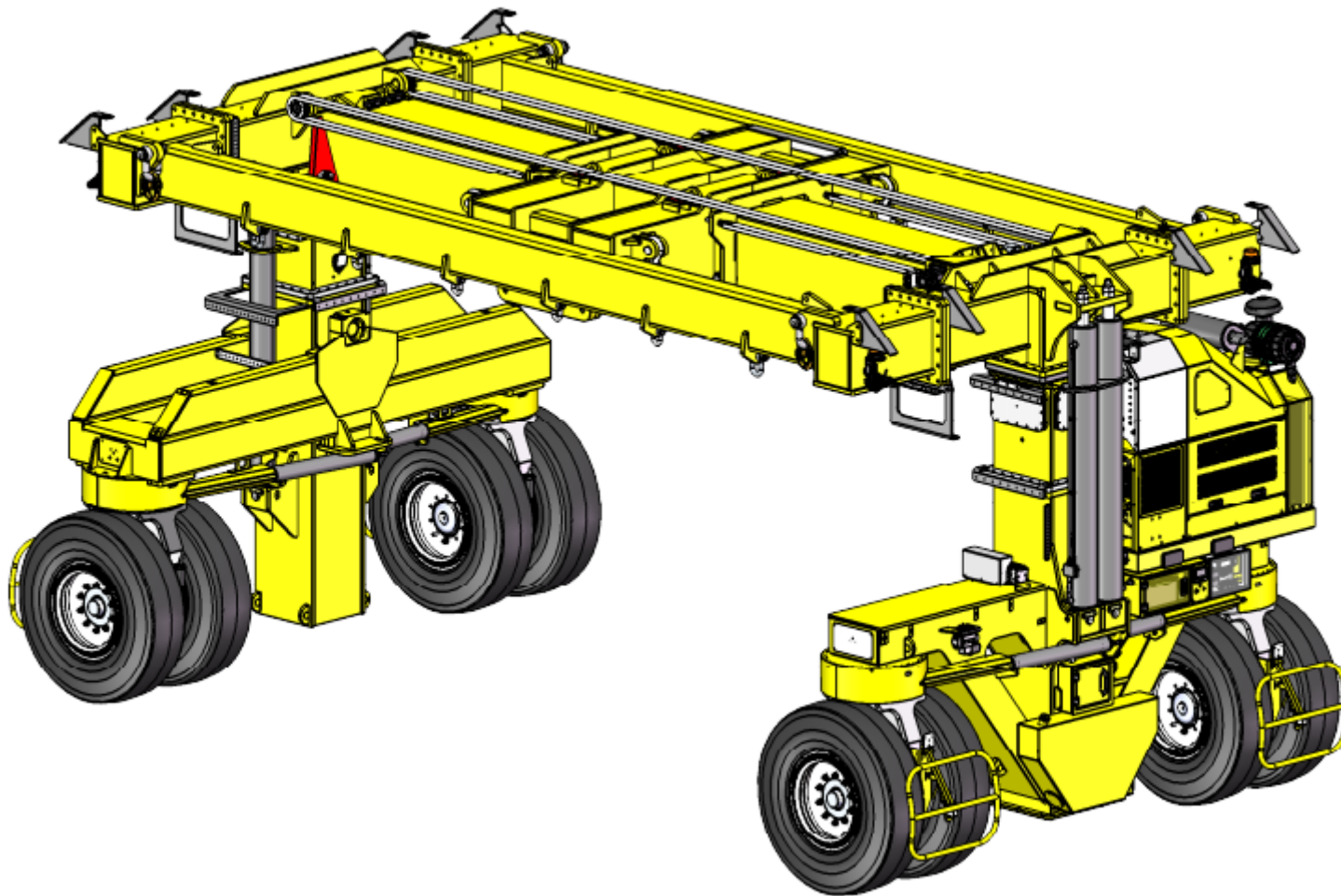

**COMBiLiFT**  
LIFTING INNOVATION

**PROJECT**  
DRY HIRE

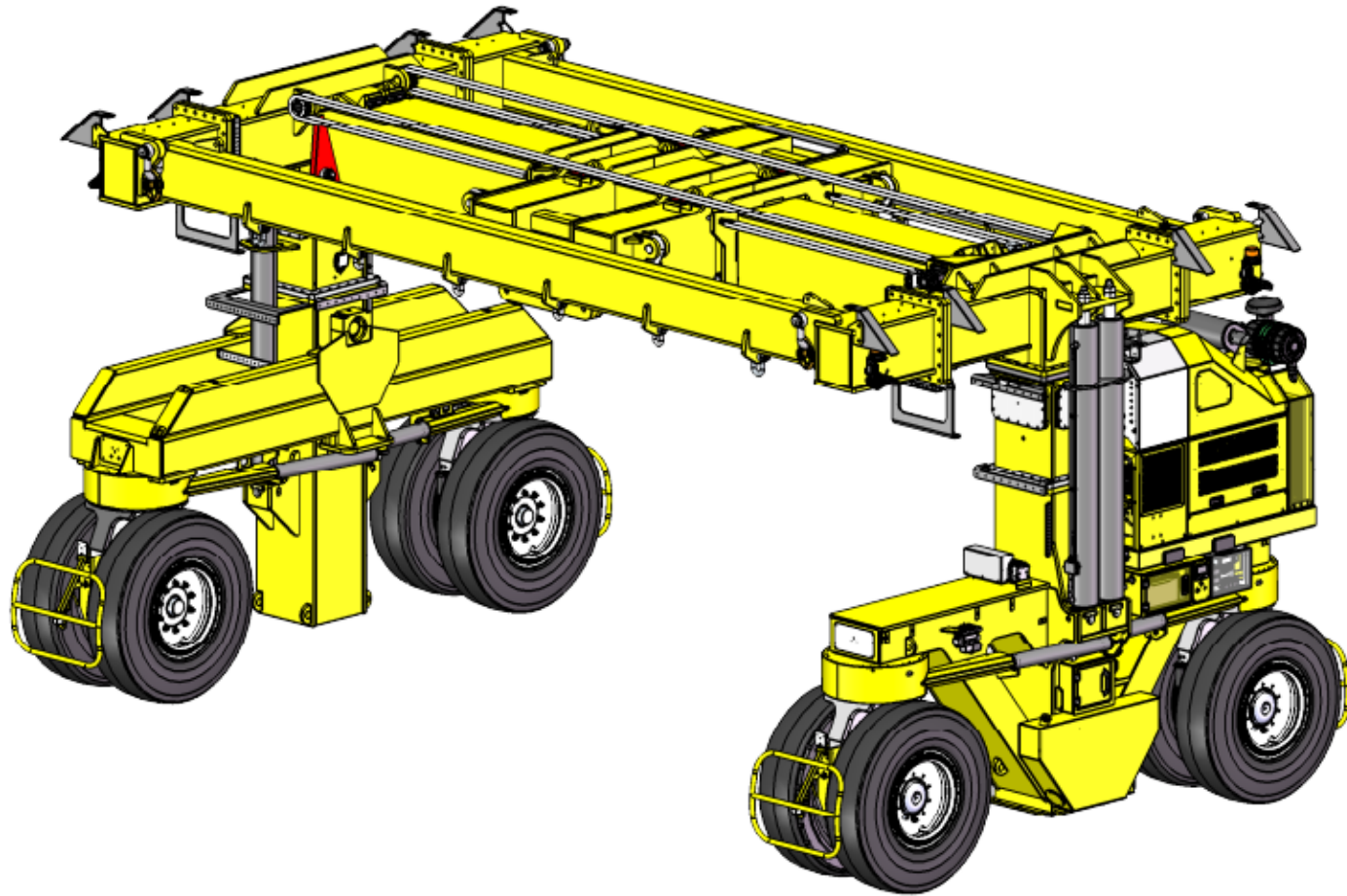

**COMBiLiFT**  
LIFTING INNOVATION

**PROJECT**  
DRY HIRE

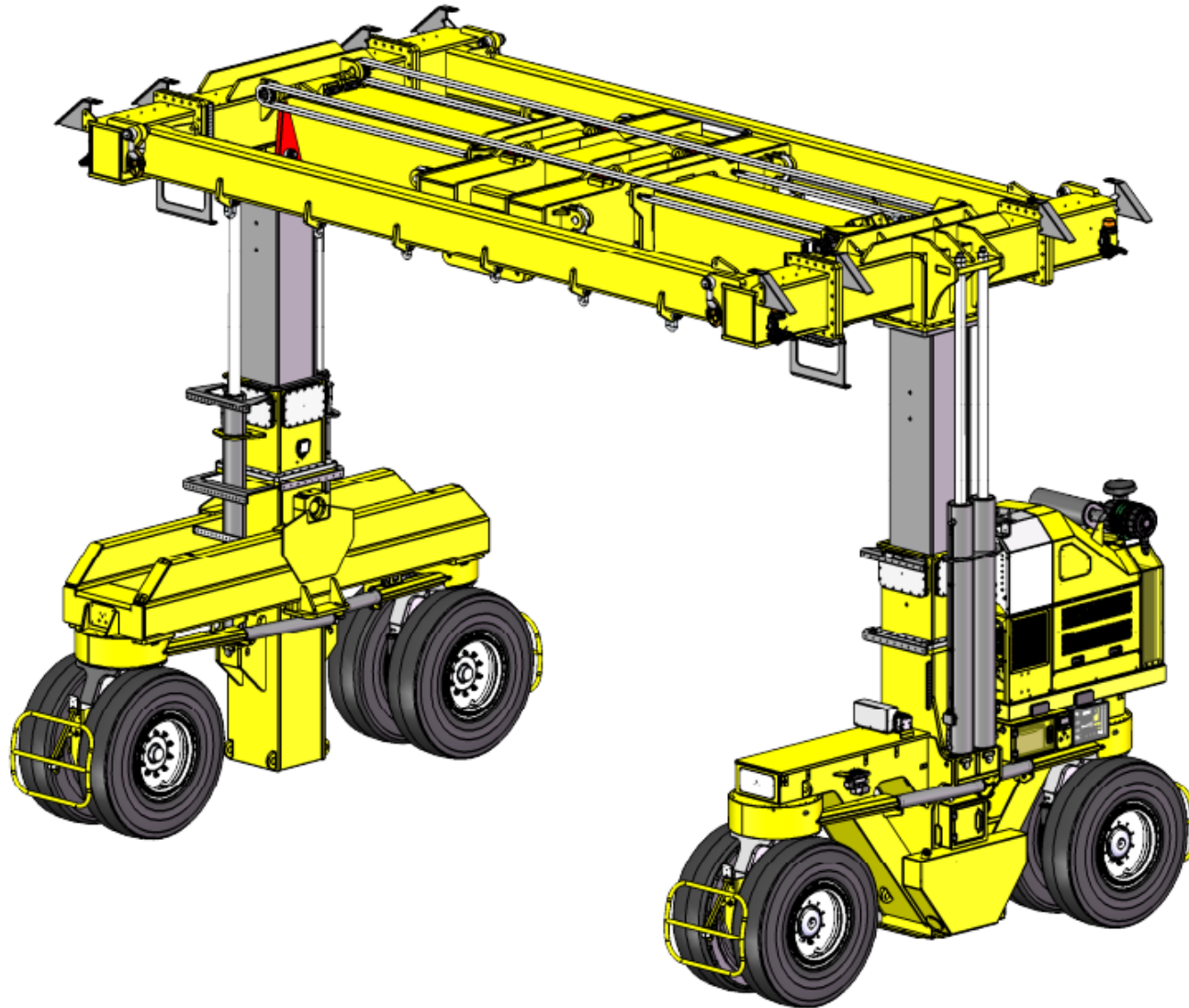

**COMBiLiFT**  
LIFTING INNOVATION

**PROJECT**  
DRY HIRE

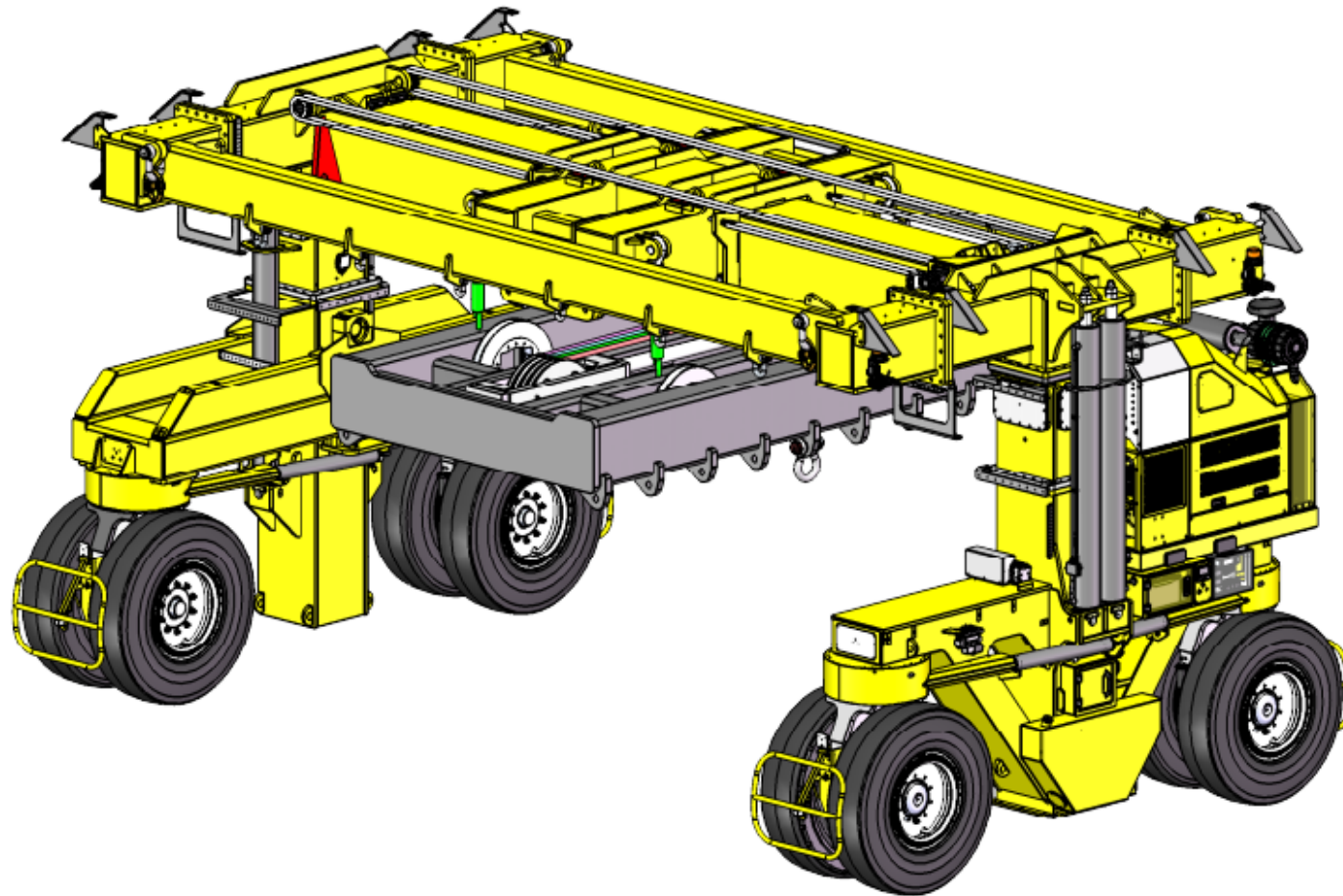

FIXED FRAME ATTACHMENT WITH  
INTERGRATED 2m LIFTSTROKE

**COMBiLiFT**  
LIFTING INNOVATION

**PROJECT**  
DRY HIRE

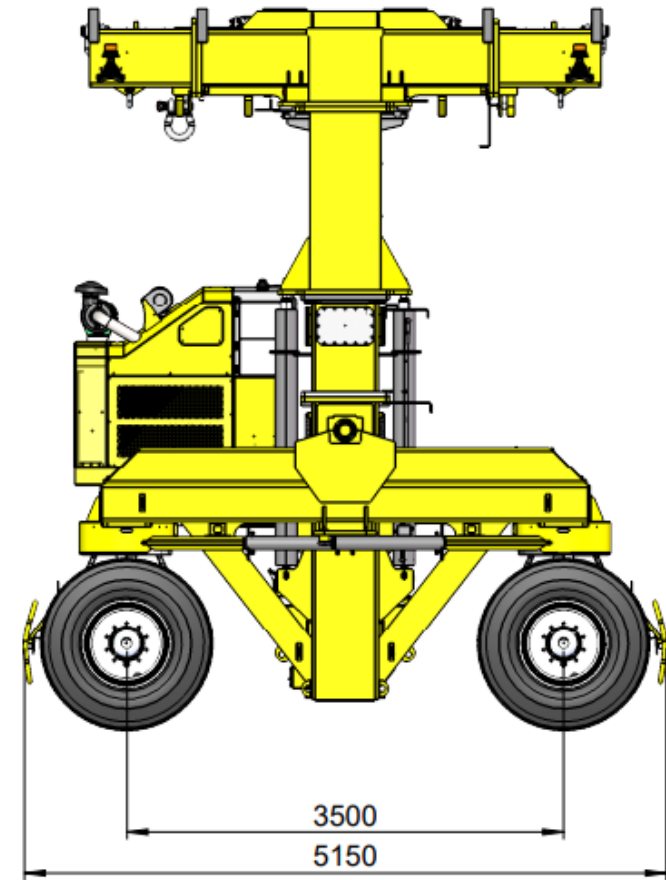
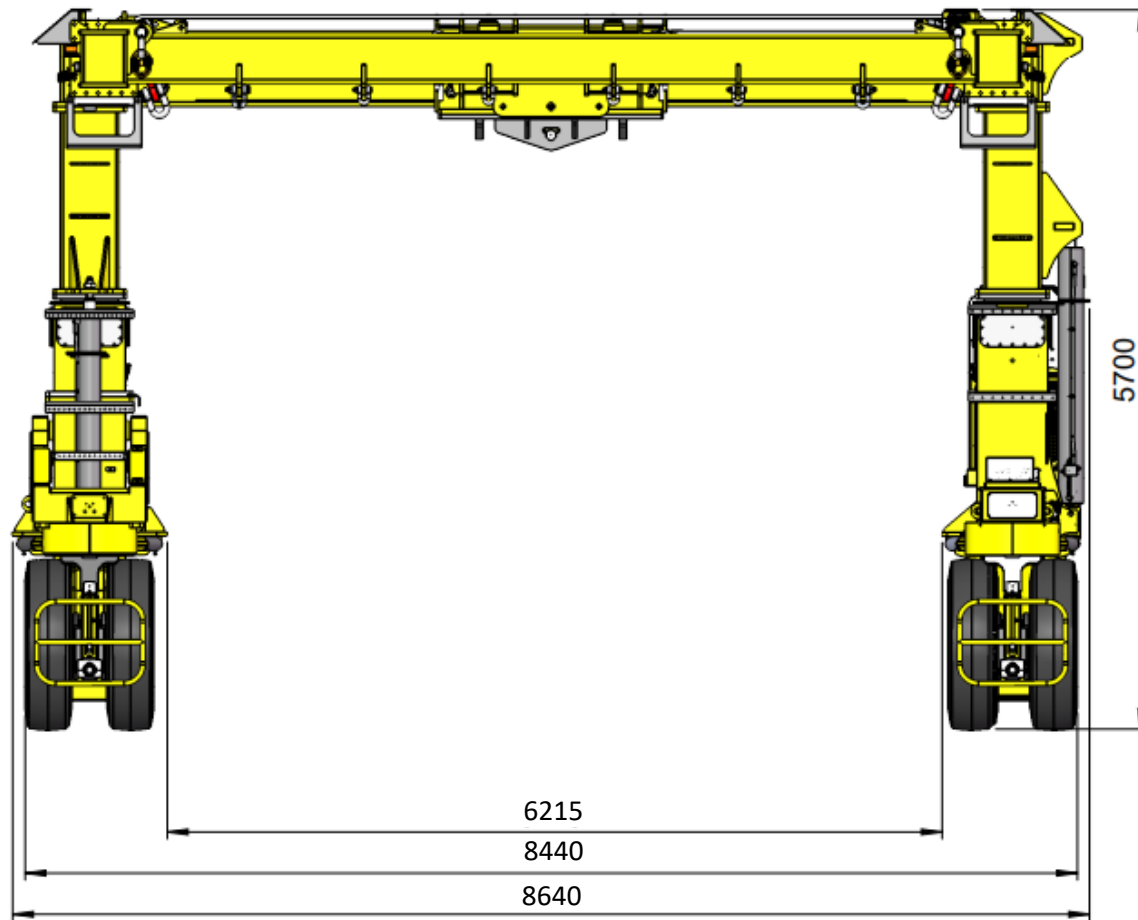

EXTENSION STOOLS FITTED

**COMBiLiFT**  
LIFTING INNOVATION

**PROJECT**  
DRY HIRE

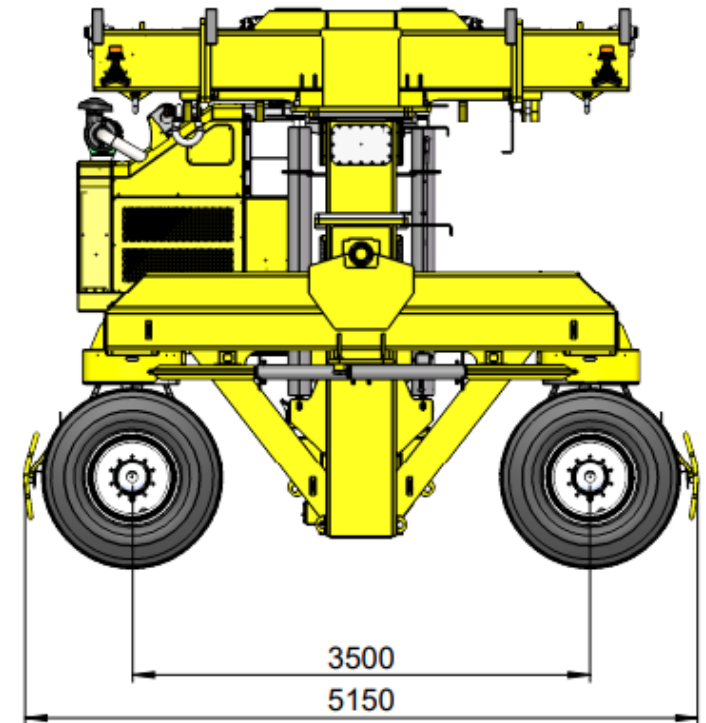
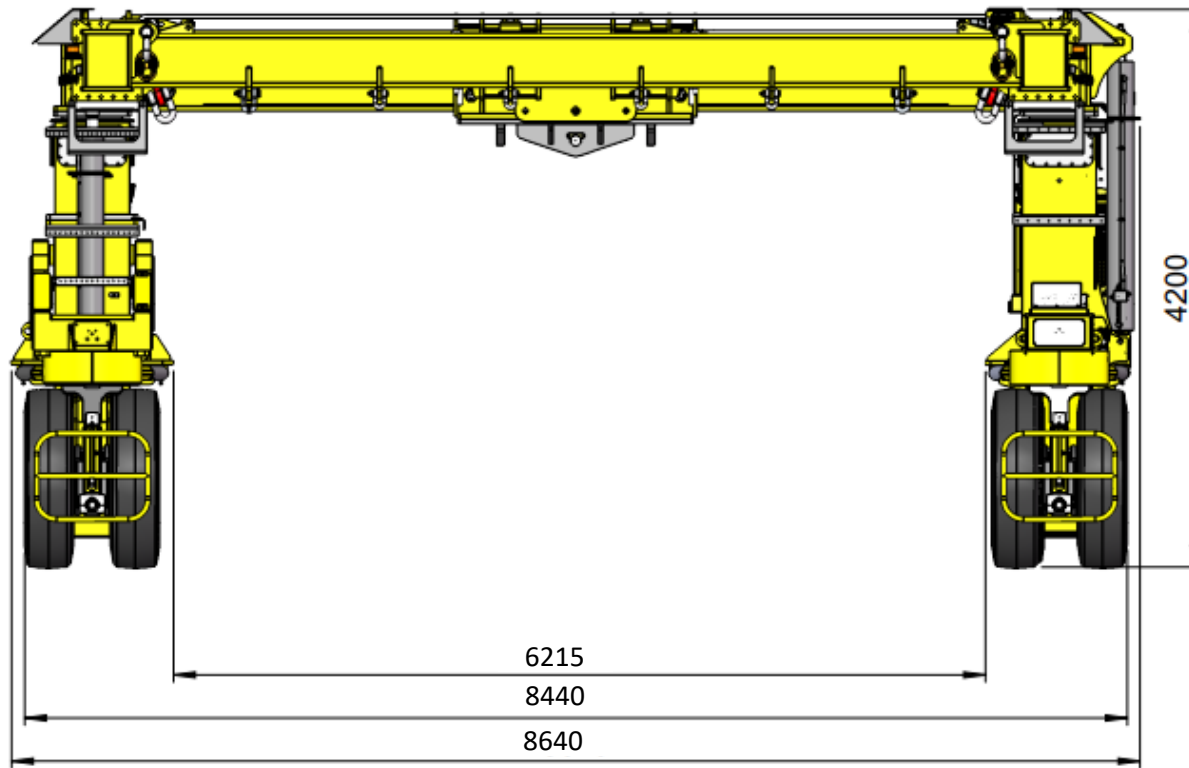

**COMBiLiFT**  
LIFTING INNOVATION

**PROJECT**  
DRY HIRE

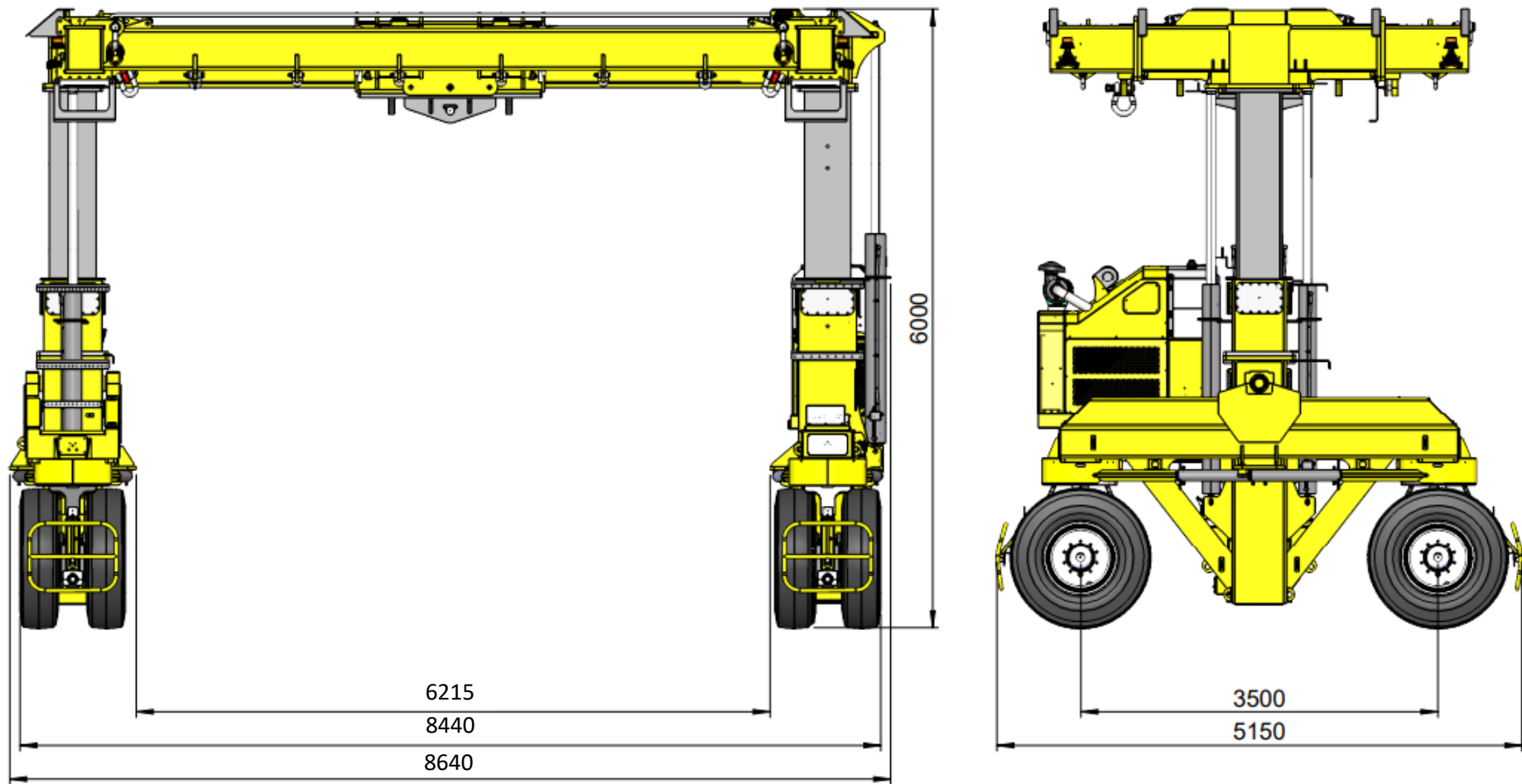

**COMBiLiFT**  
LIFTING INNOVATION

**PROJECT**  
DRY HIRE

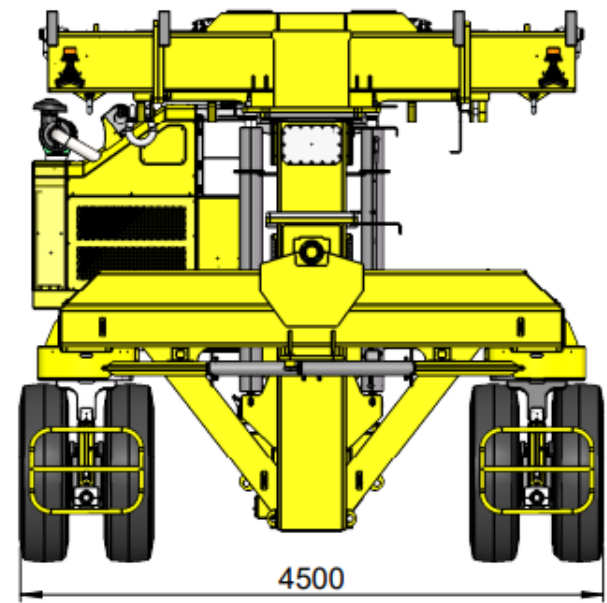
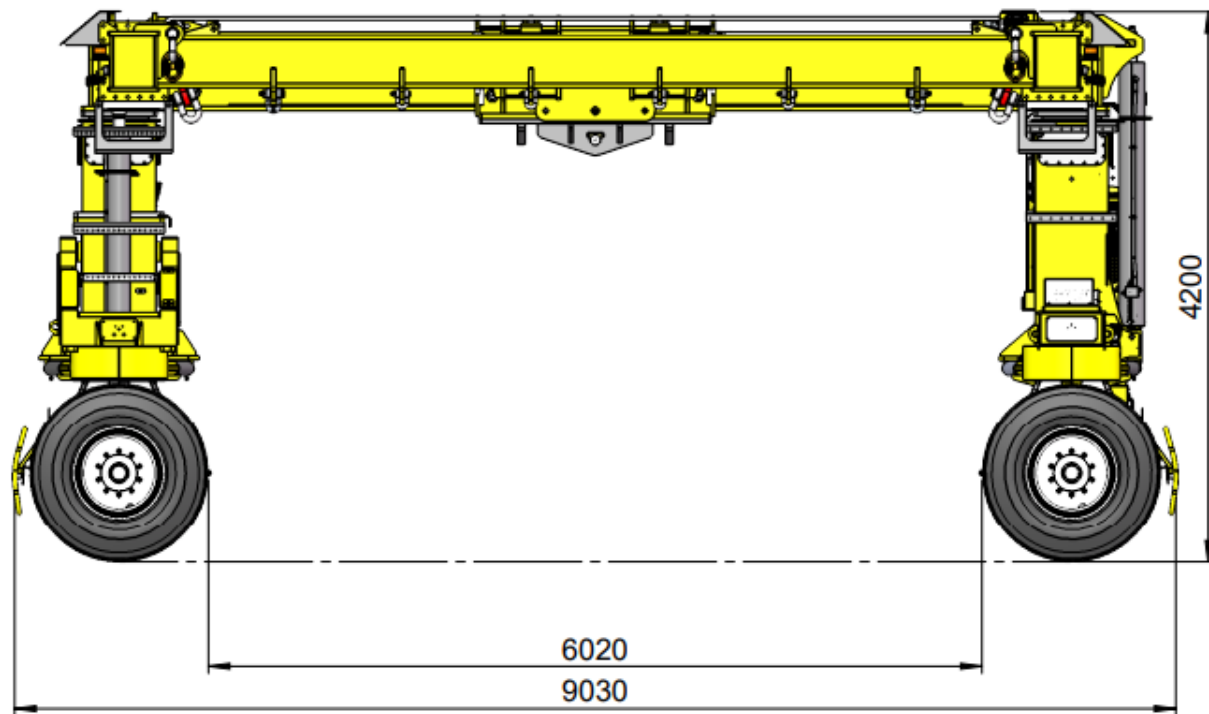

**COMBiLiFT**  
LIFTING INNOVATION

**PROJECT**  
DRY HIRE

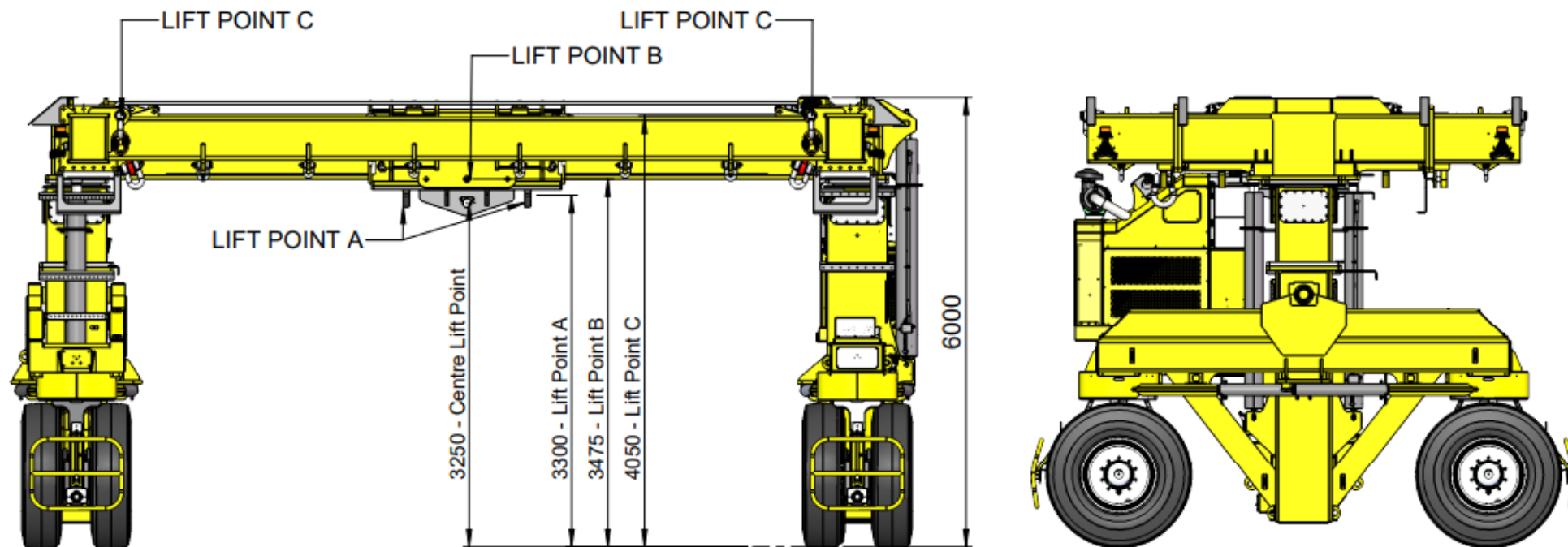

**COMBiLiFT**  
LIFTING INNOVATION

**PROJECT**  
DRY HIRE

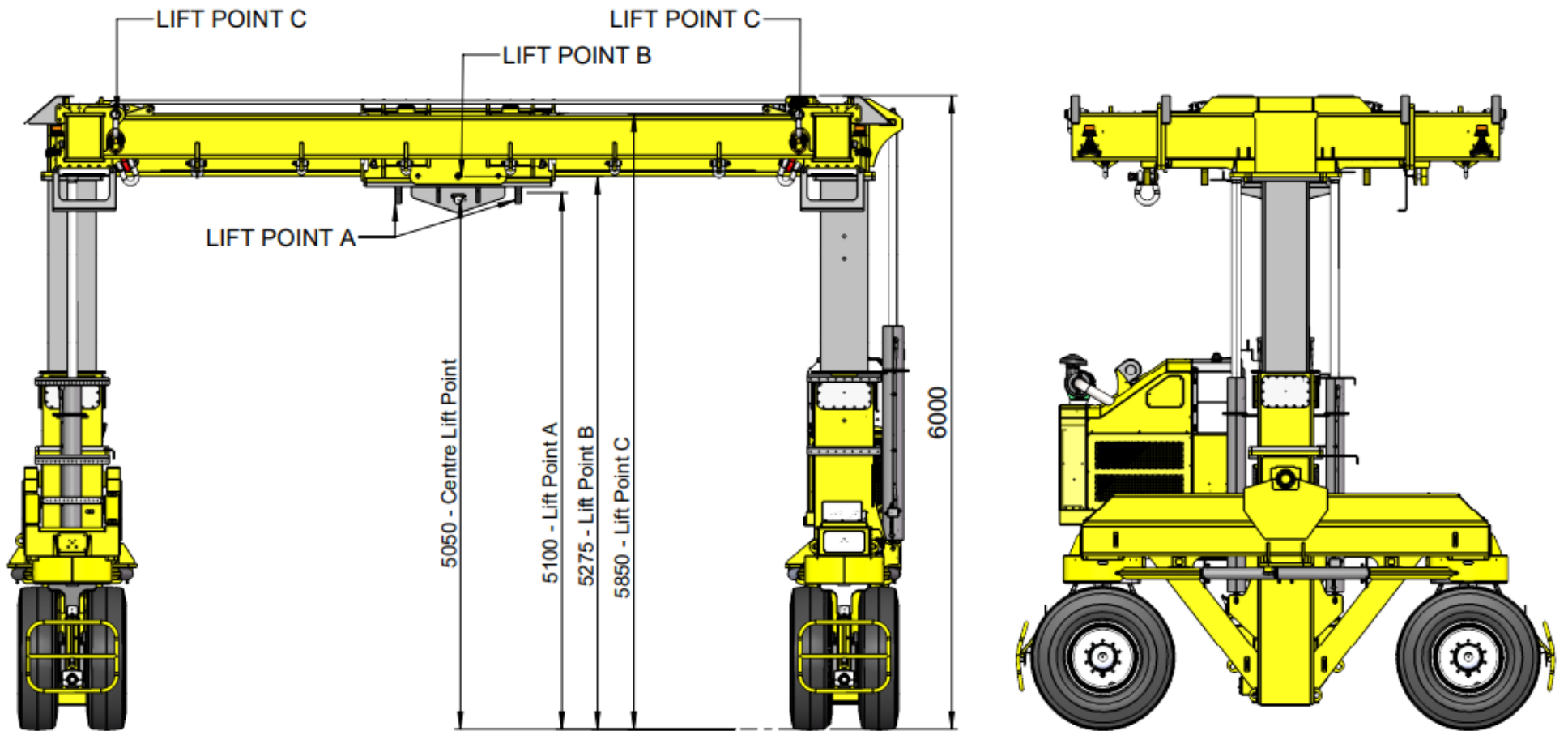

**COMBiLiFT**  
LIFTING INNOVATION

**PROJECT**  
DRY HIRE

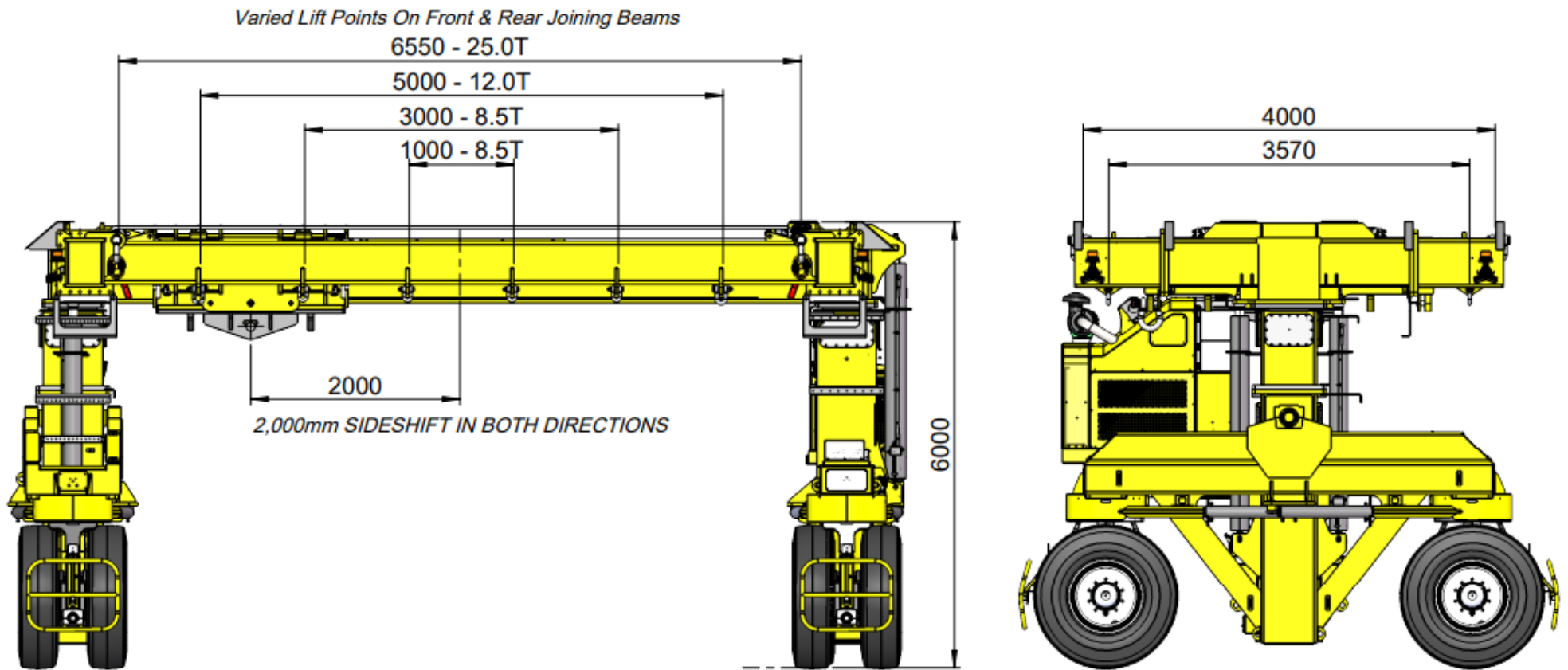

**COMBiLiFT**  
 LIFTING INNOVATION

**PROJECT**  
 DRY HIRE

90,000kg Load

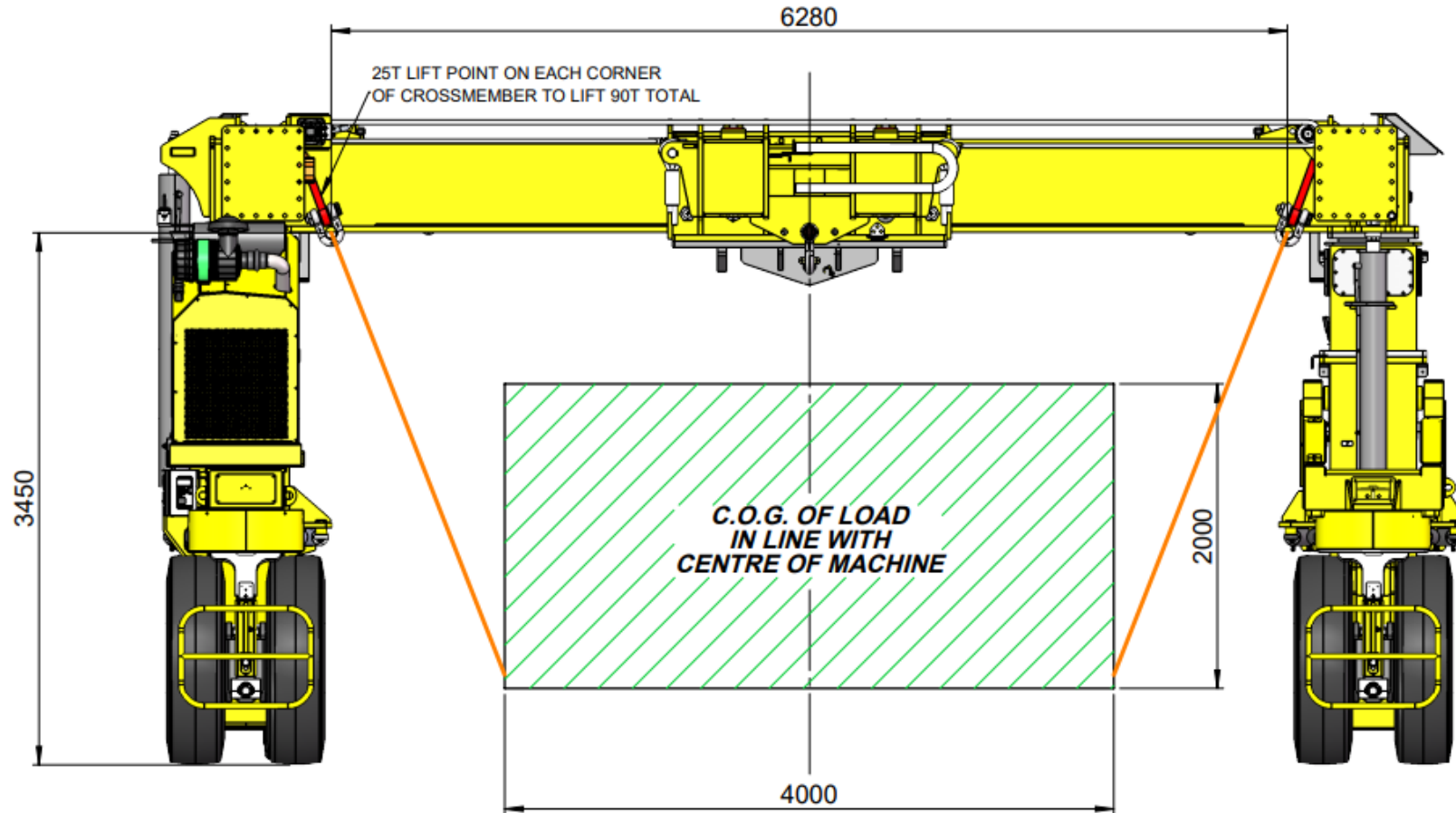

- MG Maximum Lift Capacity 90,000kg @ 5% Duty Cycle
- Maximum 2% Gradient When Transporting 90,000kg
- Critical Requirement That Load C.O.G. is in Centre of MG During Lifts
- All 90,000kg Loads Must be Lifted on x4 25,000kg W.L.L. Liftpoints on Crossmember
- Steering Modes Must Not be Changed When Loaded to 90,000kg(Lower Load to Change Steer Modes)
- Travel Distances Must be Kept as Short as Possible When Transporting 90,000kg

**COMBiLiFT**  
LIFTING INNOVATION

**PROSECT**  
DRY HIRE

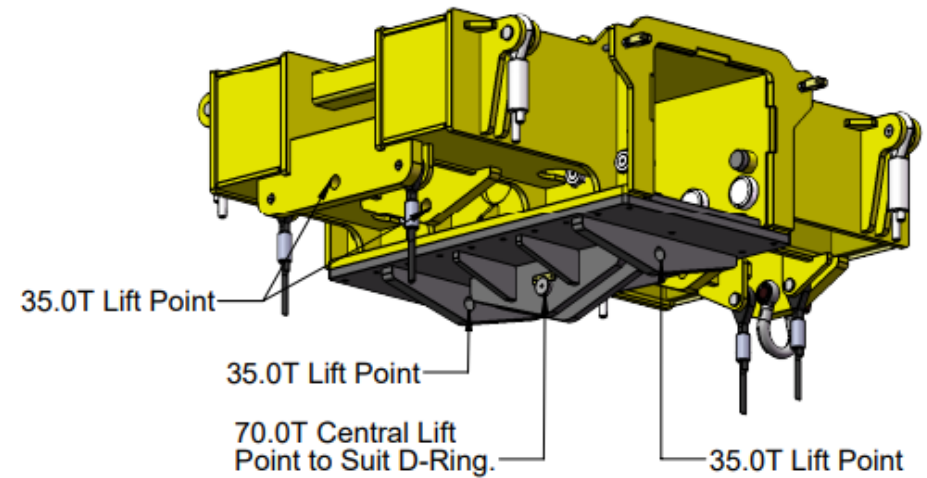
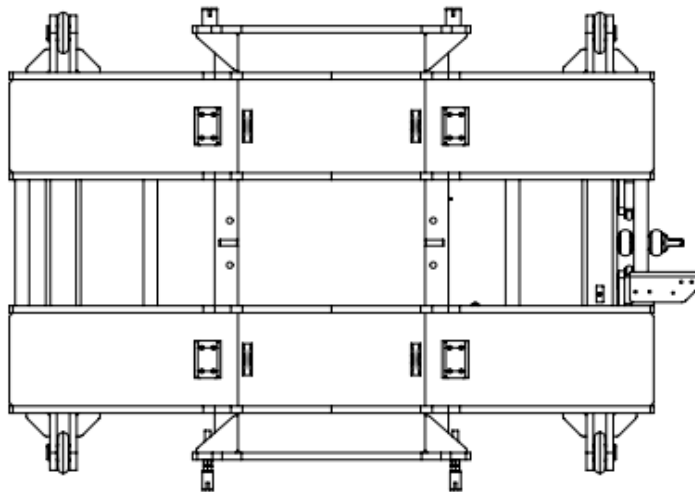
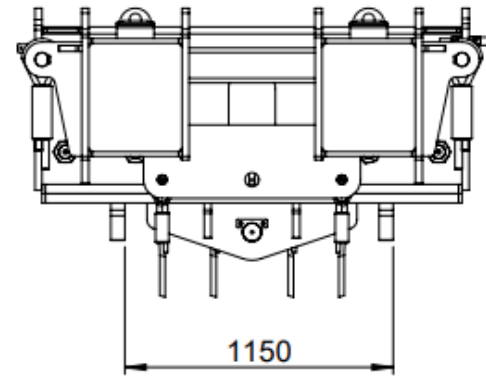
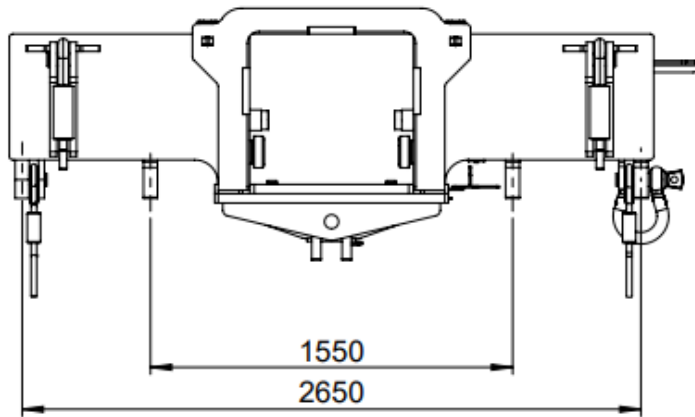

**COMBiLIFT**  
LIFTING INNOVATION

**PROJECT**  
DRY HIRE

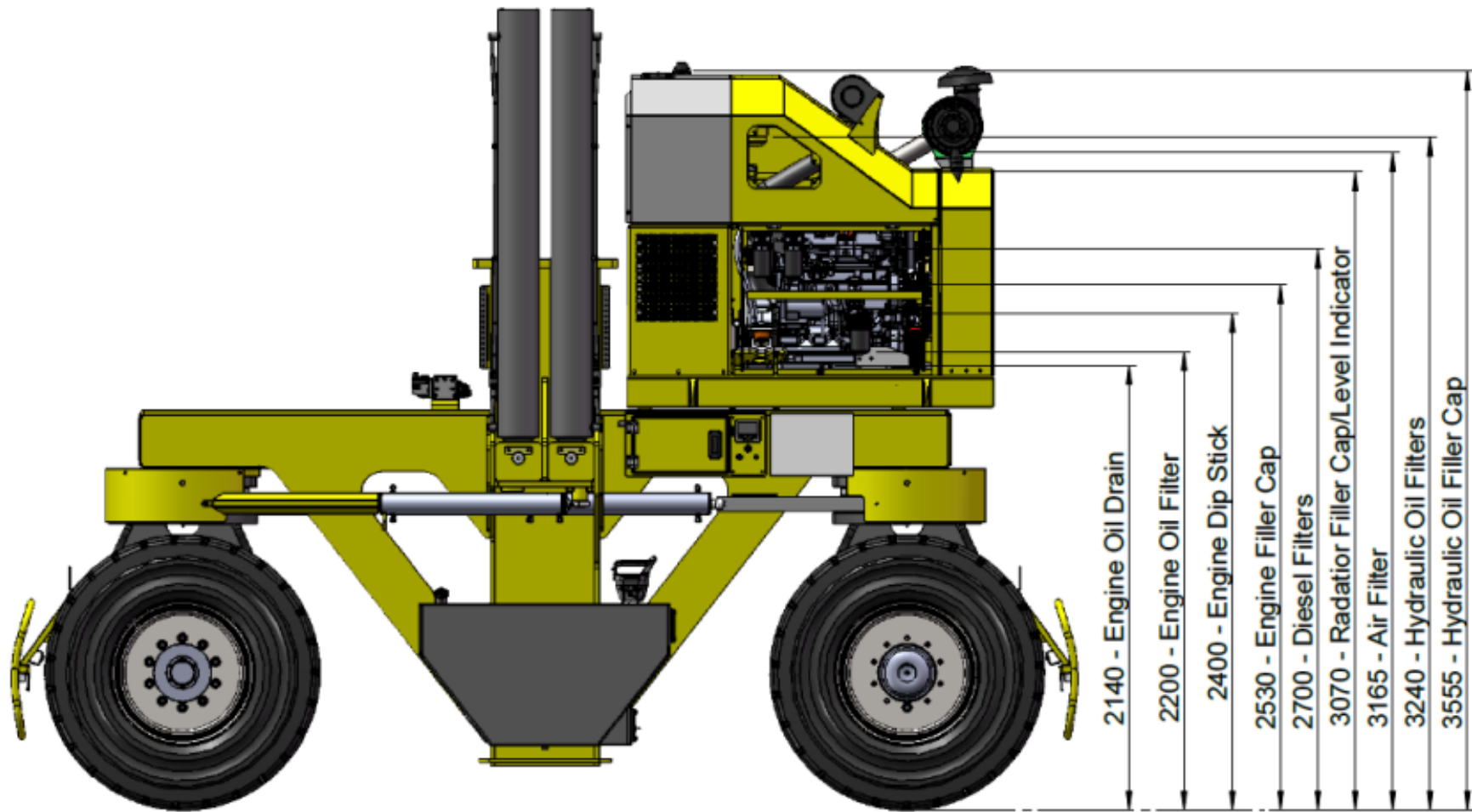

**COMBiLiFT**  
LIFTING INNOVATION

**PROJECT**  
DRY HIRE

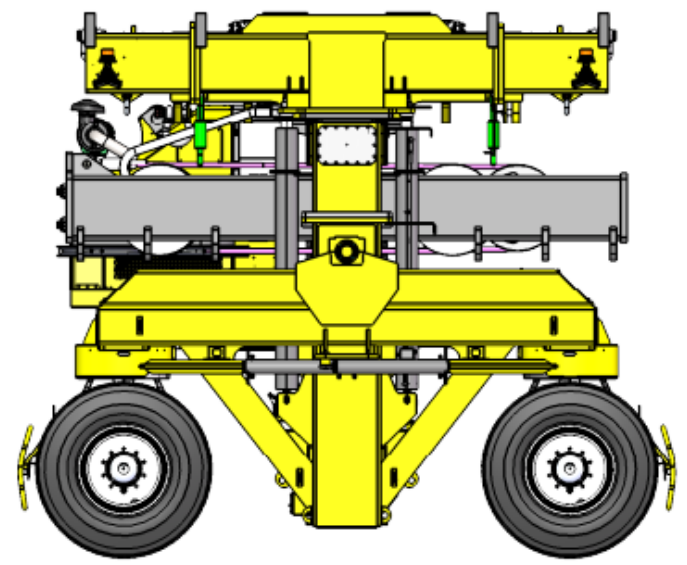
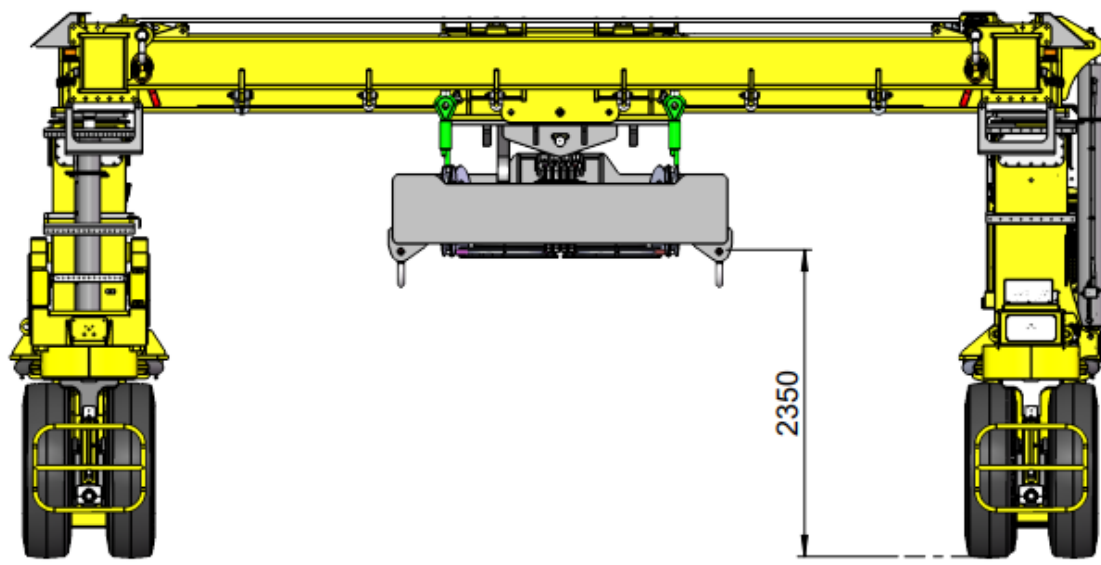

**COMBiLiFT**  
LIFTING INNOVATION

**PROSECT**  
DRY HIRE

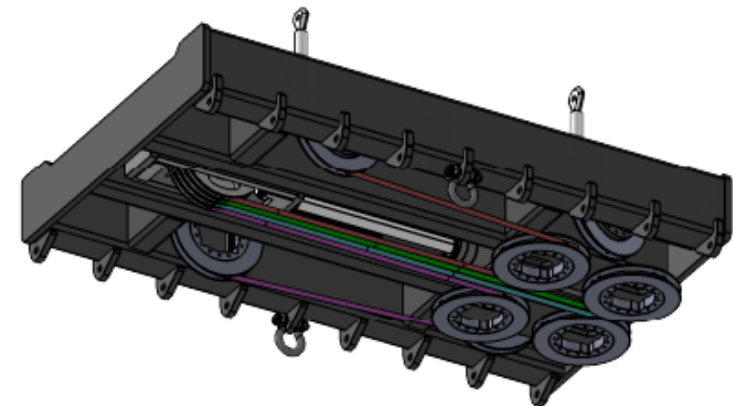
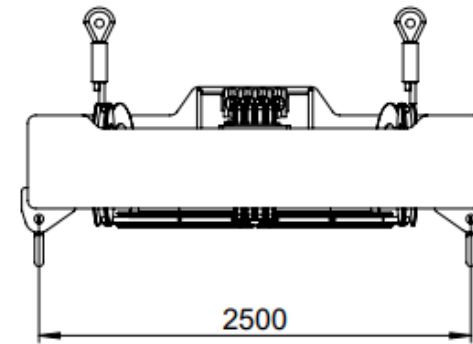
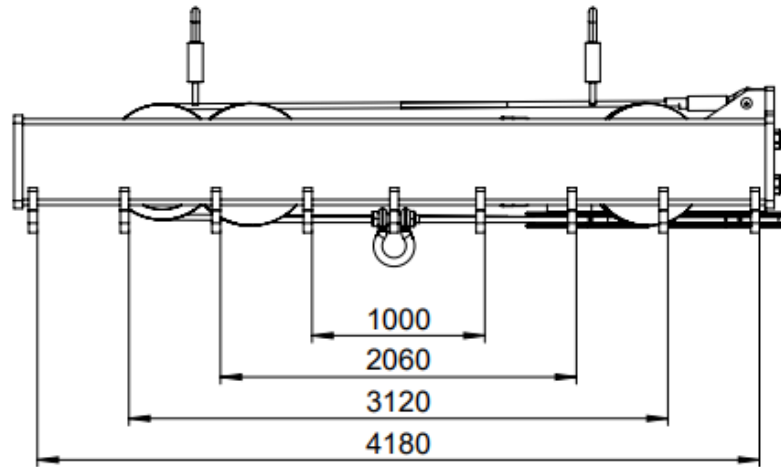

- 2m Lift Stroke
- Central 35t Lift Points
- All Other Lift Points 25t
- 1.5m Sideshift Left & Right
- When Attachment is fitted
- 60,000kg Capacity

**COMBiLiFT**  
LIFTING INNOVATION

**PROJECT**  
DRY HIRE